



3JH5E Series

Configuration	4-stroke, vertical, water-cooled diesel engine		
Maximum output at crankshaft	28.7 kW@3000 rpm	[38.5 mhp@3000 rpm]	
Displacement	1.642 ltr	[100 cu in]	
Bore x stroke	88 mm x 90 mm	[3.46 in x 3.54 in]	
Cylinders	3 in line		
Combustion system	Direct injection		
Aspiration	Natural aspiration		
Starting system	Electric starting 12V - 1.4 kW		
Alternator	12V – 125A		
Cooling system	Fresh water cooling by centrifugal fresh water pump and rubber impeller sea water pump		
Lubrication system	Enclosed, forced lubricating system		
Direction of rotation [crankshaft]	Counterclockwise viewed from flywheel side		
Dry weight without gear	173 kg	[381 lbs]	
Environmental	EU: RCD	BSO II	EMC
Engine mounting	Rubber type flexible mounting		

NOTE:Fuel condition: Density at 15°C = 0.84 g/cm³: 1 kW = 1.3596 mhp = 1.3410 HP

Fuel temperature 40°C at the inlet of the fuel injection pump [ISO 8665: 2006]

Technical data is according to ISO 8665: 2006/3046-1

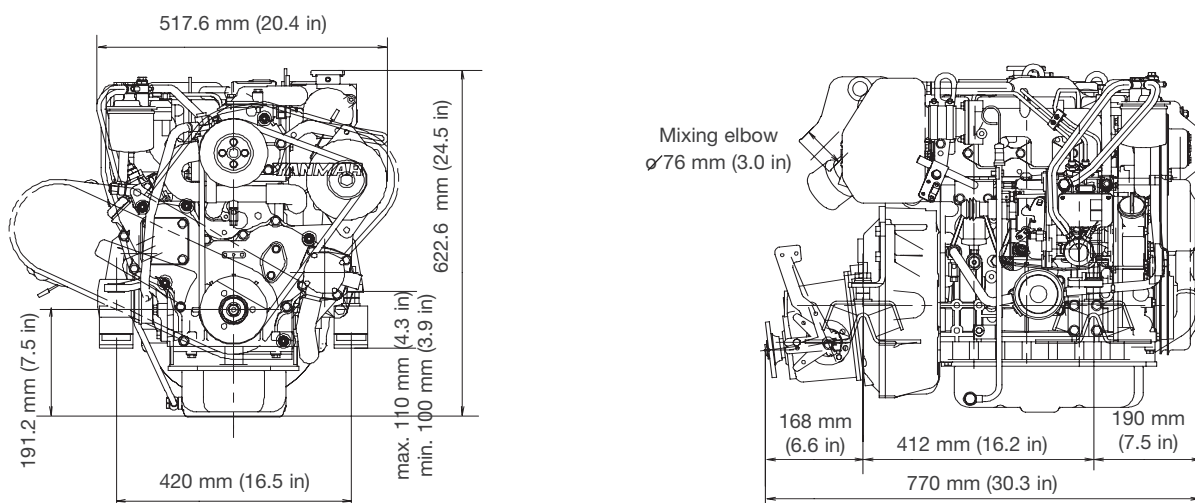
DIMENSIONS

3JH5E with KM35A marine gear



PERFORMANCE CURVES

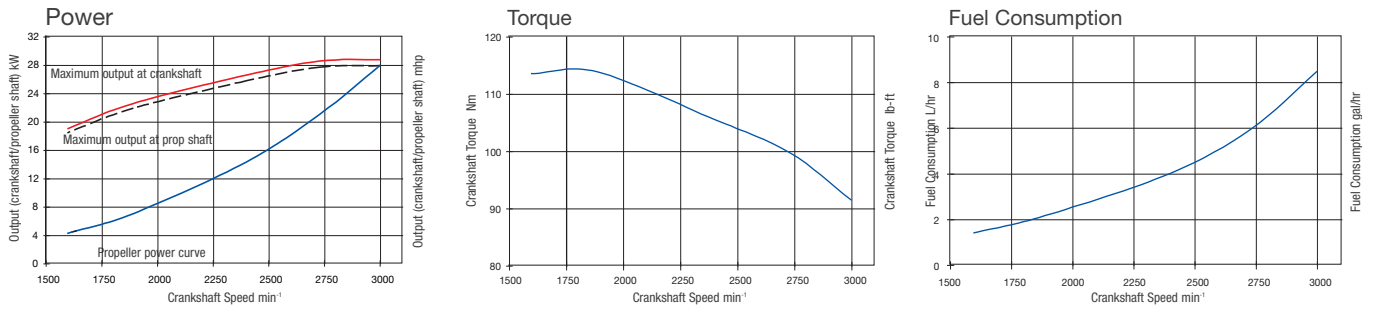

MARINE GEARS/DRIVE

Model	KM35P		KM35A (DOWN ANGLE: 7DEG)		SAILDRIVE (SD60)	
Type	Mechanical cone clutch		Mechanical cone clutch		Mechanical wet type multi-disc	
Dry Weight	12 kg [27 lbs]		13 kg [29 lbs]		40 kg [88 lbs]	
Reduction Ratio [fwd/asn]	2.36/3.16	2.61/3.16	2.33/3.04	2.64/3.04	2.23/2.23	2.49/2.49
Propeller speed [fwd/asn]	1271/949	1149/949	1288/987	1136/987	1345/1345	1205/1205
Direction of rotation [propeller shaft - fwd]	Clockwise viewed from the stern		Clockwise viewed from the stern		Clockwise & Counterclockwise viewed from flywheel side	
Dry weight - engine & gear	185 kg [408 lbs]		186 kg [410 lbs]		213 kg [470 lbs]	
Length engine and gear/drive	777 mm [31 in]		776 mm [31 in]		1019 mm [40 in]	

INSTRUMENT PANELS

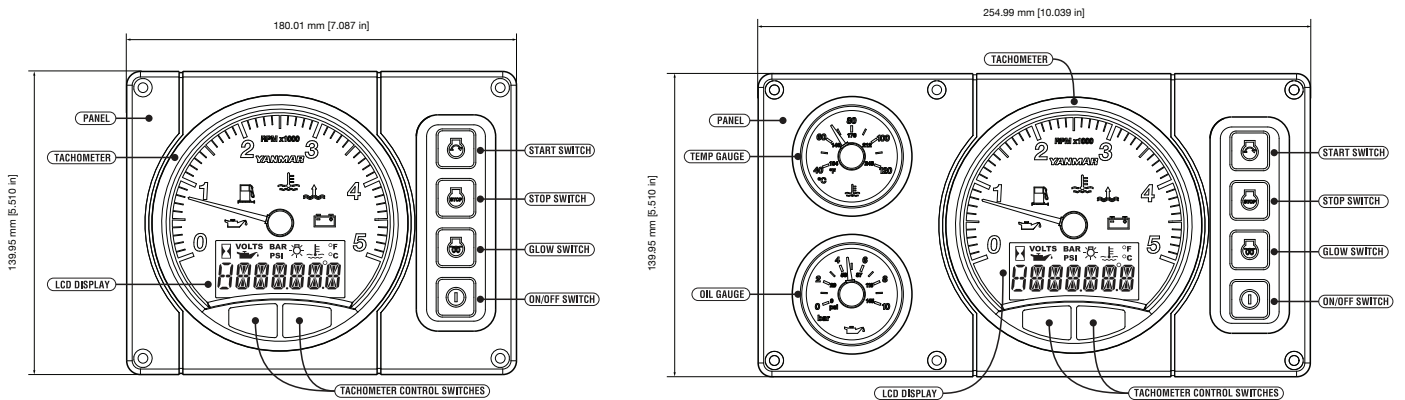

B20 STANDARD

C30 OPTIONAL

ACCESORIES

Standard engine package

- Set of flexible engine mounts
- Exhaust mixing elbow [L-type]
- V-belt safety cover
- Fresh water expansion tank
- Alternator 12V - 125A
- Electric stop solenoid
- Operation manual
- B20-panel
- Sensor for instrument panel

Optional accessories

- Second alternator 12V - 130A or 24V - 75A incl. smart regulator
- High-riser mixing elbow [instead of L-elbow]
- Hot water kit with cocks
- Second station harness
- C30-panel
- Sensor for C30-panel
- Extension saildrive leg [75 mm]
- Extension wire harness [4m, 6m 10m]
- Propeller cone nut kit SD60

NOTE: All data subject to change without notice. Text and illustrations are not binding.